

# FreeSpeak II O2 1.9 GHz Beltpack

FreeSpeak II Wireless Solutions

Linking  
People  
Together



FSII-BP19-02

## Key Features and Benefits

### Beltpack

- Functions with FreeSpeak BASE-II, FreeSpeak Edge Base, Arcadia Central Station and Eclipse HX via E-IPA cards
- 1.9, 2.4 and 5.0 GHz beltpacks operate on a single system
- Supports up to 200 beltpacks on a single system (see Capacity Chart for details)
- Encoder Volume Swap between A&C and B&D
- “Listen Again” message replay
- Simple 2-channel partyline operation to 5-channel intercom on the same beltpack
- Over-the-air beltpack registration

### Connectivity

- 1.9 GHz radio frequency
- Typical range 300ft (90m), outdoor range 800ft (240m)
- Robust radio link works in high multipath or reflective environments

### Mechanical

- IP53 rating for wet and dusty conditions
- 18+ hour battery life or USB port for continuous operation

FreeSpeak II® is a high performance wireless solution operating in the 1.9 and 2.4 GHz frequency bands designed for extensive communication in large-scale operations.

## Description

The FSII O2 1.9 GHz beltpack is specifically designed to work in Hyperbaric chambers safely, operating at atmospheric pressures of 5.1 atm, 517 kPa, or 75 psi with a change of +/- 26 psi per minute without damage.

## Operation

The FSII-BP19-02 can connect to the FreeSpeak II Base Station, FreeSpeak Edge Base Station, Arcadia Central Station or to the Eclipse® HX matrices using the E-IPA-HX interface card. FSII-BP19 users can roam seamlessly between FSII-TCVR-19 or FSII-TCVR-IP-19 transceivers over wide areas. The “Listen Again” feature allows users to replay earlier commands, eliminating the need to repeat communication or disturb productions. Volume Swap allows for independent level control on channels A, B, C, and D listens.

## Increase System Size

The FSII-BP19-X4-O2 can be used interchangeably with any other FreeSpeak II or FreeSpeak Edge beltpack on the same system. Depending on what system you connect to, you can increase the quantities of beltpack users that operated on a single system (see Capacity Chart for details).

## Durability

The FSII-BP19-X4-O2 is IP53 rated for water and dust protection with special components to withstand depths of 125 ft (38 m). For better grip and protection, the beltpack has a rubberized over-mold to protect it from the most rugged environments.

## Battery

The FSII-BP24-X4-O2 beltpack does not support the AC60 battery like the FSII-BP19 and FSII-BP24 beltpacks. Because this beltpack is used in high-pressure environments, the FSII-BP19-X4-O2 will only support the use of three AA alkaline or rechargeable Nickel Metal Hydride batteries. Beltpack battery level settings will accommodate to the use of these batteries.

# FreeSpeak II O2 1.9 GHz Beltpack

FreeSpeak II Wireless Solutions

## Capacity Chart

	Max Number of Supported Beltpacks	Max Number of Supported TCVRs	Max Number of BPs per TCVR
FreeSpeak II Base II 5Up	5	2 (E1) 10 (via E1 Splitters)	5 (E1)
FreeSpeak II Base II	25	2 (E1) 10 (via E1 Splitters)	5 (E1)
FreeSpeak Edge Base	16	6 (IP) 2 (E1) 10 (via E1 Splitters)	5 (E1) 10 (IP)
Arcadia Central Station	40	16 (IP) 2 (E1) 10 (via E1 Splitters)	5 (E1) 10 (IP)
Eclipse HX (via E-IPA Cards)	192 Delta 200 Median/Omega	192 Delta (IP) or 30 (via E1 Splitters) 256 Median (IP) or 40 (via E1 Splitters) 320 Omega (IP) or 50 (via E1 Splitters)	5 (E1) 10 (IP)

\*Note: Each E-IPA Card can support up to 64 BPs and 64 TCVRs (IP) or 50 BPs and 10 TCVRs (E1)

## Technical Specifications

### Audio

**Audio Bandwidth:** 200Hz-7.5kHz

**No. of Full-Duplex Audio Paths:** Up to 5 with individual level control (2 dedicated rotaries, 3 with menu), 2 controls and a main volume

**Mode of Operation:** Full duplex on all routes

**Level/Talk Controls:** 4 pushbuttons, a reply button and 2 rotary controls

**Enter/Answer-Back Button:** 1

### Frequency Spectrum

**USA, Canada, Mexico:** 1920-1930MHz (5 Channels)

**Transceiver Range Output Power:** 100mW

**EU, Russia, Singapore, Hong Kong, Australia, New Zealand, South Africa:**

1880-1900MHz (5 Channels)

**Transceiver Range Output Power:** 250mW

**Japan:** 1893-1906MHz (2 Channels)

**Transceiver Range Output Power:** 250mW

**Argentina, Bahamas:** 1910-1930MHz (10 Channels)

**Transceiver Range Output Power:** 250mW

**Brazil:** 1910-1930MHz (5 Channels)

**Transceiver Range Output Power:** 250mW

**Chile:** 1910-1930MHz (5 Channels)

**Transceiver Range Output Power:** 70mW

**Taiwan:** 1880-1895MHz (8 Channels)

**Transceiver Range Output Power:** 250mW

### Connectors

**Headset Connector:** 4-pin male

**Microphone Type:** Electret and Dynamic, selectable in beltpack menu

**Headset Limiter:** Selectable from beltpack menu

**Max Distance (Beltpack To Transceiver, Indoor):**

~300-500ft (90-150m)

**Max Distance (Beltpack To Transceiver, Outdoor):**

~800-1500ft (240-450m)

### Power

**Modulation:** GFSK, TDMA frame 10ms Full and Long slot

**Output power:** (EU/Russia) 10dBm average, (US) 18-20dBm

**Range:** Typical indoor range 300ft (90m), outdoor range 800ft (240m)

**Battery:** 3 AA alkaline or Nickel Metal Hydride

**Battery Life:** 9+ hours

### Environmental

IP53 water and dust resistance

**Operating:** 32°-125°F (0°-50°C)

**Storage:** 32°-150°F (0°-70°C)

**Humidity:** Between 20% and 90%, Non-Condensing

Atmospheric pressures of 5.1 atm or 75 psi

### Dimensions

Tapered design at largest points

3.9 x 5.1 x 1.8in (HxWxD)

(99 x 129.5 x 45.7mm)

### Weight

9.0oz (0.25kg) including batteries

# FreeSpeak II O2 1.9 GHz Beltpack

FreeSpeak II Wireless Solutions

Front

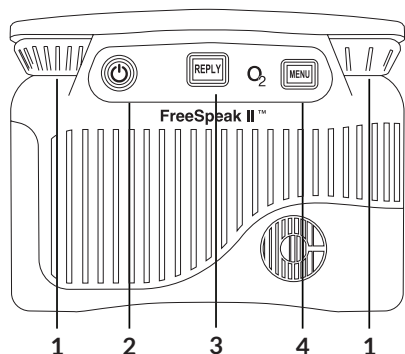

Back

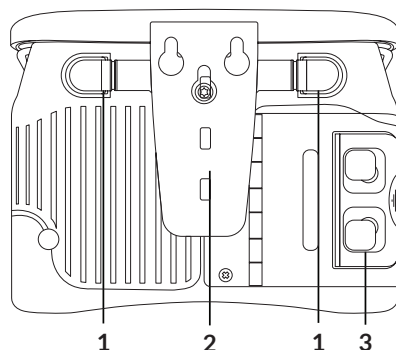

Top

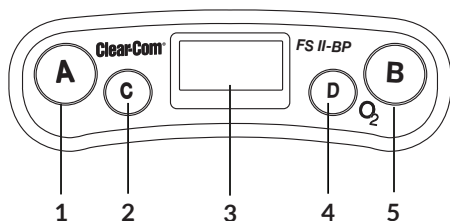

Bottom

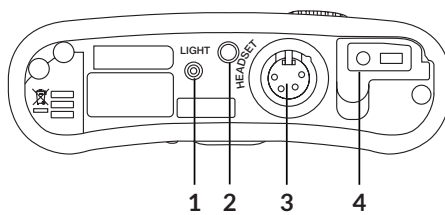

## Legend

### Front

1. Volume control
2. Power button
3. Reply button
4. Menu button

### Back

1. Shoulder strap hook
2. Belt clip
3. Battery door

### Top

1. Channel A
2. Channel C
3. LCD
4. Channel D
5. Channel B

### Bottom

1. Flashlight
2. Flashlight switch
3. Headset connector
4. USB and Audio Jack connectors

## Order Codes

Approved for use in USA & Canada:

FSII-BP19-X4-02-US  
FSII-BP19-X5-02-US  
FSII-BP19-X7-02-US

Approved for use in EU:

FSII-BP19-X4-02-EU  
FSII-BP19-X5-02-EU  
FSII-BP19-X7-02-EU

Approved for use in Brazil:

FSII-BP19-X4-02-B  
FSII-BP19-X5-02-B

Approved for use in Latin America:

FSII-BP19-X4-02-LA  
FSII-BP19-X5-02-LA



[www.clearcom.com/  
freespeakii-knowledge-center/](http://www.clearcom.com/freespeakii-knowledge-center/)



[www.clearcom.com](http://www.clearcom.com)

© 2022 Clear-Com LLC. All rights reserved.  
FreeSpeak II, Clear-Com, and the Clear-Com logo are  
registered trademarks of Clear-Com LLC.

**Notice About Specifications** | While Clear-Com makes every attempt to maintain the accuracy of the information contained in its documentation, that information is subject to change without notice. Performance specifications included in this document are design-center specifications and are included for customer guidance and to facilitate system installation. Actual operating performance may vary.

**WARNING:** Cancer and Reproductive Harm - [www.P65Warnings.CA.Gov](http://www.P65Warnings.CA.Gov)