



# INTERFACE MODULE FRAMES

IMF-3, IMF-102, DIF-102

# INSTRUCTION MANUAL

Interface Module Frames Instruction Manual  
© 2007 Vitec Group Communications Ltd. All rights reserved.

Part Number 810313Z Rev. 3

Vitec Group Communications, LLC.  
850 Marina Village Parkway  
Alameda, CA 94501  
U.S.A

Vitec Group Communications  
7400 Beach Drive  
Cambridge Research Park  
Cambridgeshire  
United Kingdom  
CB25 9TP

Vitec Group Communications  
Room 1806, Hua Bin Building  
No. 8 Yong An Dong Li  
Jian Guo Men Wai Ave  
Chao Yang District  
Beijing, P.R. China 100022

® Clear-Com, CellCom/FreeSpeak and the Clear-Com Communication Systems logo are registered trademarks of The Vitec Group plc.

# CONTENTS

<b>OPERATING AN INTERFACE FRAME . . . . .</b>	<b>1-1</b>
Interface Frames and Modules . . . . .	1-1
IMF-3 Interface Module Frame . . . . .	1-1
Front Panel . . . . .	1-1
PSU-101 Power Supply . . . . .	1-2
Modular Connector Panels . . . . .	1-2
IMF-102 Interface Module Frame . . . . .	1-2
DIF-102 Digital-Station Interface Module Frame . . . . .	1-3
Interfaces Supported for IMF-3 and IMF-102 Frames . . . . .	1-4
Interfaces Supported for DIF-102 Digital-Station Interface Frame . . . . .	1-4
<b>POWERING INTERFACES . . . . .</b>	<b>2-1</b>
Introduction . . . . .	2-1
Power Supplies . . . . .	2-1
Redundant Power . . . . .	2-1
Powering Interfaces in an IMF-102 Frame . . . . .	2-1
Powering Interfaces in a DIF-102 Frame . . . . .	2-2
Powering Interfaces in an IMF-3 Frame . . . . .	2-2
The PSU-101 Power Supply . . . . .	2-2
PSU-101 Front-Panel Controls and Lights . . . . .	2-3
Power Status Lights . . . . .	2-3
+ Analog . . . . .	2-3
- Analog . . . . .	2-4
Fuses . . . . .	2-4
Audible Alarm . . . . .	2-4
PSU-101 Rear-Panel Connectors . . . . .	2-4
Connector to Mains AC Power . . . . .	2-4
Alarm Relay . . . . .	2-5
Power to Interface Frame (2 Connectors for Redundancy) . . . . .	2-5
Installing the PSU-101 Power Supply . . . . .	2-6
PSU-101 Powering of Interfaces in an IMF-3 Frame . . . . .	2-6
<b>INSTALLATION . . . . .</b>	<b>3-1</b>
Placing Interface Frames and Power Supplies . . . . .	3-1
Step-by-Step Installation . . . . .	3-1
IMF-3 Interface Frame . . . . .	3-1
IMF-102 and DIF-102 Interface Frames . . . . .	3-2
PSU-101 Power Supply . . . . .	3-2
Wiring . . . . .	3-3

IMF-102 Interface Frame . . . . .	3-3
DIF-102 Digital-Station Interface Frame. . . . .	3-3
PSU-101 Power Supply . . . . .	3-4
<b>SPECIFICATIONS. . . . .</b>	<b>4-1</b>
IMF-3 Interface Frame . . . . .	4-1
IMF-102 Interface Frame . . . . .	4-1
DIF-102 Interface Frame. . . . .	4-2
PSU-101 Power Supply . . . . .	4-2
<b>LIMITED WARRANTY . . . . .</b>	<b>5-1</b>
Warranty Period. . . . .	5-i
Technical Support . . . . .	5-i
Warranty Repairs and Returns . . . . .	5-ii
Non-Warranty Repairs and Returns. . . . .	5-ii
Extended Warranty . . . . .	5-ii
Liability. . . . .	5-iii

# IMPORTANT SAFETY INSTRUCTIONS

*Please read and follow these instructions before operating this product.*

1. Read these instructions.
2. Keep these instructions.
3. Heed all warnings.
4. Follow all instructions.
5. Do not use this apparatus near water.
6. Clean only with dry cloth.
7. Do not block any ventilation openings. Install in accordance with the manufacturer's instructions.
8. Do not install near any heat sources such as radiators, heat registers, stoves, or other apparatus (including amplifiers) that produce heat.
9. Do not defeat the safety purpose of the polarized or grounding-type plug. A polarized plug has two blades, with one wider than the other. A grounding-type plug has two blades and a third grounding prong. The wide blade or the third prong are provided for your safety. If the provided plug does not fit into your outlet, consult an electrician for replacement of the obsolete outlet.
10. Protect the power cord from being walked on or pinched particularly at plugs, convenience receptacles, and the point where they exit from the apparatus.
11. Only use attachments/accessories specified by the manufacturer.
12. Use only with the cart, stand, tripod, bracket, or table specified by the manufacturer, or sold with the apparatus. When a cart is used, use caution when moving the cart/apparatus combination to avoid injury from tip-over.
13. Unplug this apparatus during lightning storms or when unused for long periods of time.
14. Refer all servicing to qualified service personnel. Servicing is required when the apparatus has been damaged in any way, such as power-supply cord or plug is damaged, liquid has been spilled or objects have fallen into the apparatus, the apparatus has been exposed to rain or moisture, does not operate normally, or has been dropped.
15. **WARNING:** To reduce the risk of fire or electric shock, do not expose this product to rain or moisture.

Please familiarize yourself with the safety symbols in Figure 1. When you see these symbols on this product, they warn you of the potential danger of electric shock if the main station is used improperly. They also refer you to important operating and maintenance instructions in the manual.



This symbol alerts you to the presence of uninsulated dangerous voltage within the product's enclosure that might be of sufficient magnitude to constitute a risk of electric shock. Do not open the product's case.



This symbol informs you that important operating and maintenance instructions are included in the literature accompanying this product.

*Figure 1: Safety Symbols*

## EMC AND SAFETY

The Interface Module Frames meet all relevant CE, FCC, UL, and CSA specifications set out below:

EN55103-1 Electromagnetic compatibility. Product family standard for audio, video, audio-visual, and entertainment lighting control apparatus for professional use. Part 1: Emissions.

EN55103-2 Electromagnetic compatibility. Product family standard for audio, video, audio-visual, and entertainment lighting control apparatus for professional use. Part 2: Immunity.

UL 60065-7, CAN/CSA-C22.2 No.60065-3, IEC 60065-7 Safety requirements.

And thereby compliance with the requirement of Electromagnetic Compatibility Directive 2004/108/EC and Low Voltage Directive 2006/95/EC

This device complies with Part 15 of the FCC Rules. Operation is subject to the following two conditions: (1) this device may not cause harmful interference, and (2) this device must accept any interference received, including interference that may cause undesired operation.

# OPERATING AN INTERFACE FRAME

## INTERFACE FRAMES AND MODULES

An interface module converts the 4-wire signals transmitted from a central matrix port to other types of signals that communicate with such external devices as telephones, camera intercoms, two-way radios, and so on.

To house these interface modules, Clear-Com offers three interface frames:

- The IMF-3 interface frame
- The IMF-102 interface frame
- The DIF-102 interface frame

*An interface converts central matrix signals into other forms to communicate with telephones, camera intercoms, two-way radios, and other devices.*

### IMF-3 INTERFACE MODULE FRAME

An IMF-3 interface module frame:

- Houses up to 11 Eclipse matrix interface modules.
- Installs in 3 rack units (3 RU) of a standard 19-inch wide (48.26 cm) equipment rack.
- Provides power to its interfaces through the externally connected PSU-101 power supply.

#### Front Panel

The front panel of the IMF-3 frame contains 11 slots for inserting interfaces. Figure 1-1 shows an unpopulated IMF-3 frame. (When unpopulated, an interface slot is covered with a blank panel.)

*Clear-Com offers three types of frames to house interfaces: the IMF-3, IMF-102, and DIF-102. Each is described in this product guide.*

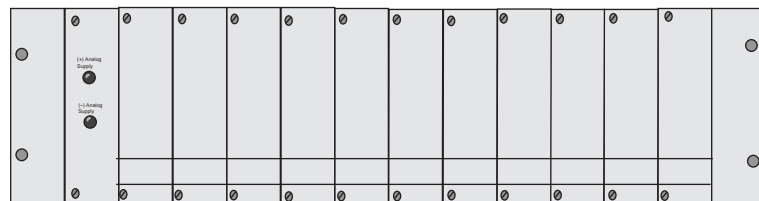

Figure 1-1: Front Panel of an IMF-3 Interface Frame

The IMF-3 interface frame itself has only two front-panel lights to indicate the flow of DC power to the frame's interfaces. The two lights represent the plus and minus analog power supplies used by some interfaces.

Each individually installed interface module will have its own front-panel lights and controls.

## PSU-101 Power Supply

Powering an IMF-3 frame's interfaces requires an externally connected PSU-101 power supply. Each Eclipse central matrix contains its own power supplies and does not supply any power for interfaces.

A single PSU-101 provides enough DC voltage to power the interfaces in two IMF-3 frames, depending on the type of interfaces present and their individual power requirements. Additional PSU-101 power supplies can be installed for redundancy.

The PSU-101 installs in one rack unit (1 RU) of a standard 19-inch wide (48.26 cm) equipment rack. Chapter 2, "Powering Interfaces," provides more information on installing and operating the PSU-101 power supply.

## Modular Connector Panels

The rear panel of the IMF-3 interface frame holds up to 11 separate connector panels, one for each interface module installed in the frame. Each connector panel holds two RJ-45 sockets for connecting an interface module to matrix ports, and two DB-9 sockets for connecting an interface module to non-4-wire devices.

Figure 1-2 illustrates the rear panel of an IMF-3 interface frame, with 11 connector panels installed.

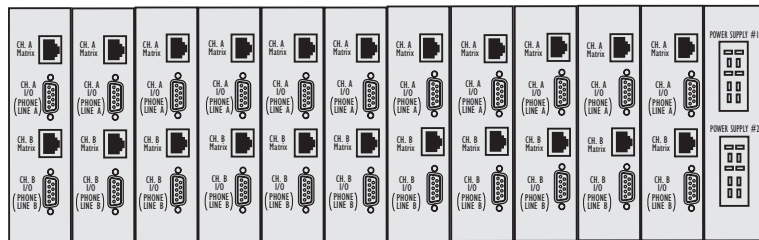

Figure 1-2: Rear Panel of IMF-3 Interface Frame

The two 10-pin Jones-type connectors on the rightmost side of the frame are for connecting external PSU-101 power supplies. One power supply will power the interfaces in one or more IMF-3 frames. A second PSU-101 can be connected for redundancy. See Chapter 2, "Powering Interfaces," for more information.

*Note: The IMF-3 frame has an individual rear panel for each interface. All interfaces use the same rear panel; however the use of the rear-panel connectors will vary with the type of interface. The Clear-Com part number for this rear panel is 710538.*

## IMF-102 INTERFACE MODULE FRAME

The IMF-102 interface frame houses two interface modules in one rack unit (1 RU) of a standard 19-inch wide (48.26 cm) equipment rack.



An internal power supply provides DC voltage to the interfaces. For redundant power, a rear-panel 10-pin Jones-type connector is provided for attaching an external power supply to the interface frame.

Two green lights on the IMF-102 frame's front panel illuminate to show the presence of DC power at the frame. The two lights represent the plus and minus analog power supplies used by some interfaces.

Each installed interface will have its own front-panel lights and controls.

Modular rear-connector panels connect the interfaces to the central matrix and to external devices. Each rear-connector panel has two RJ-45 sockets for connecting cable to the central matrix and two DB-9 sockets for connecting cable to external devices.

Figure 1-3 illustrates the front and rear panels of an IMF-102 interface frame, with two installed rear-panel assemblies.

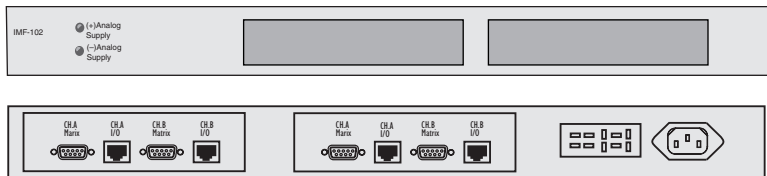

Figure 1-3: IMF-102 Interface Frame Front and Rear Panels

## DIF-102 DIGITAL-STATION INTERFACE MODULE FRAME

The DIF-102 interface frame has slots for two digital DIG-2 interface modules in one rack unit (1 RU) of a standard 19-inch (48.26 cm) equipment rack. DIG-2 interface modules allow the matrix to connect to digital versions of Clear-Com intercom stations.

The DIF-102 frame is powered by one or two (for redundancy) external AC mains to 24-VDC power supplies via locking DIN connectors on the DIF-102's rear panel. All other voltages are derived directly or indirectly from the 24 VDC on the DIG-2 module's front and rear cards.

The DIF-102 should be located in the same building as the Eclipse frame. It can be located up to 3,000 feet (1000 meters) from an Eclipse frame.

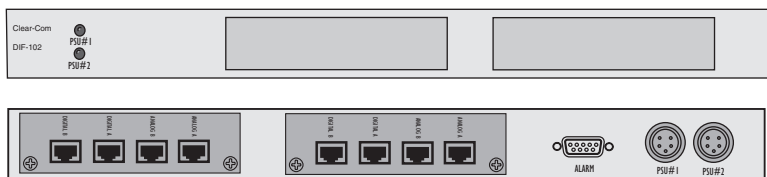

Figure 1-4: DIF-102 Digital Station Interface, Front and Rear Panels

## INTERFACES SUPPORTED FOR IMF-3 AND IMF-102 FRAMES

- **FOR-22** A two-channel, universal 4-wire interface with transformer isolation, opto-isolation for logic input, and relay contacts for logic out.
- **CCI-22** A two-channel, isolated translator of 4-wire audio from the matrix to two-wire intercom circuits, such as Clear-Com Party line products.
- **TEL-14** Allows two standard 2-wire POTS telephone lines to be connected to Matrix ports.
- **TEL-12A** A single-channel interface of 4-wire audio to a 2-wire standard analog POTS telephone line.
- **RLY-6** Provides six relays that can be wired for general purpose use and controlled directly by the matrix frame.
- **GPI-6** Provides a method to read external switch closures and control voltages and translate them to operations in the matrix frame.
- **AES-6** A digital interface for Eclipse systems allowing Eclipse panels with digital interfaces to be connected to Eclipse systems. Rear card options support both CAT5/RJ45 and Coax/BNC panel wiring.

*Note: When hot-plugging any other card in the IMF-3 interface frame all AES-6 cards in the interface frame should be reset to ensure correct operation.*

## INTERFACES SUPPORTED FOR DIF-102 DIGITAL-STATION INTERFACE FRAME

A DIF-102 interface frame holds two DIG-2 digital-station interface modules. A DIG-2 digital-station interface module allows the matrix to communicate with two Clear-Com digital intercom stations. It converts the matrix's analog port signals to digital signals for the connected digital stations.

DIG-2 interfaces are only supported by the DIF-102 interface frame and should not be fitted to any other interface frame.

The stations supported by the DIG-2 interface are:

- ICS-92T
- ICS-102T
- ICS-2003T

The ICS-92T and ICS-102T stations are standard versions of the stations with the COM-10 communications module replaced by a COM-20 module. The ICS-2003T requires different firmware in addition to the COM-20 module.

# 2

## POWERING INTERFACES

### INTRODUCTION

Each interface frame is powered by AC mains electric current transformed into the appropriate DC voltage by a power supply, either external or internal to the product. Each interface frame has provisions for power "redundancy," so that if a power supply fails, or if a branch of AC mains fails, the frame's interfaces will receive power from an alternate source.

*Each interface frame has provisions for power "redundancy," so that if a power supply fails, or if a branch of AC mains fails, the frame's interfaces will receive power from an alternate source.*

### POWER SUPPLIES

Interfaces require a power supply to transform the alternating current (AC) at the mains electric outlet to an appropriately lower direct current (DC). The IMF-102 interface frame has an internal power supply, while the DIF-102 frame has external power supplies via DIN connectors on the frame's rear panel. The IMF-3 frame requires an external power supply.

### REDUNDANT POWER

Each interface frame is equipped with an additional socket for connecting a second power-supply unit. Using two power-supply units, each connected to a separate branch of AC mains power, provides redundancy in the event of a power failure in one the AC mains branches.

Connecting two power-supply units to an interface frame also insures that a frame's interfaces will continue to receive power if one or more of the power outputs in the power supplies fail.

*The IMF-102 has an internal power supply. The DIF-102 has external power supplies via DIN connectors on the frame's rear panel. The IMF-102 requires an external power supply.*

### POWERING INTERFACES IN AN IMF-102 FRAME

An internal power supply provides DC voltage to the interfaces housed in an IMF-102 frame. The internal power supply requires 90 to 250 VAC with a maximum dissipation of 20 watts.

A 10-pin Jones-type socket for connecting an additional power supply is located on the rear panel of the IMF-102 unit. Connecting an additional power supply provides redundancy in the event of a power failure in AC mains (if each power supply is connected to a separate branch of AC mains) or in the event of equipment failure.

Figure 2-5 shows the location of the 10-pin Jones-type socket for connecting a second power supply unit.

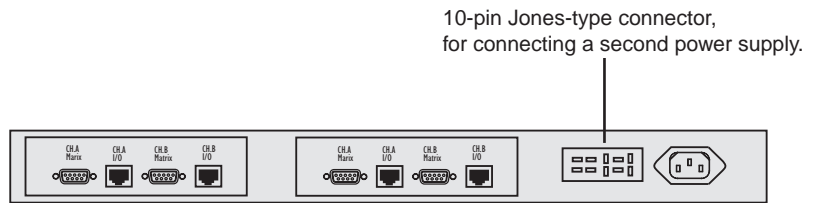

Figure 2-5: 10-Pin Jones Connector for Second Power Supply

Two green lights on the IMF-102 frame's front panel illuminate to show the presence of DC power at the frame. The two lights represent the plus and minus analog power supplies used by some interfaces.

## POWERING INTERFACES IN A DIF-102 FRAME

The DIF-102 interface frame is powered by one or two (for redundancy) external AC mains to 24-VDC power supplies via locking DIN connectors on the DIF-102's rear panel. All other voltages are derived directly or indirectly from the input 24 VDC on the DIG-2 front and rear cards.

You can connect an external alarm to the DIF-102 frame with the output provided by the Form C relay change-over contacts made available on a 9-way make D connector on the DIF-102 rear panel.

## POWERING INTERFACES IN AN IMF-3 FRAME

The IMF-3 frame requires the external PSU-101 power supply to operate. One PSU-101 power supply will provide power to two IMF-3 frames or more, depending on the type of interfaces installed. You can connect an additional PSU-101 for redundancy. Once installed, the power supply requires very little attention.

The following sections describe the operation and installation of the PSU-101 power supply, and describes in detail how the PSU-101 powers the interfaces in an IMF-3 frame.

### THE PSU-101 POWER SUPPLY

Each PSU-101 power supply contains two separate 9-VDC regulated power outputs. Each power output features adjustable output voltage. If voltage adjustment is necessary, set the outputs for 9 VDC  $\pm$  0.1 V under a 1-ampere load (this manual refers to the output voltages as 8 V; the voltages presented to the frame below the blocking diodes is actually about 8.4 to 8.5 V).

The two outputs provide "plus" and "minus" voltage for the frame's interfaces. Green status lights on the PSU-101's front panel illuminate steadily to indicate that the power outputs are operating correctly.

Each output of the PSU-101 features a fuse as listed below:

- + analog 3.0 amps
- – analog 3.0 amps

The PSU-101 features a variety of failure indicators, including:

- An audible alarm with a front panel disable switch.
- Relay contacts that can be wired to an external alarm.

Two PSU-101 units can operate in parallel to provide redundant power—if one supply fails, the entire system can continue operating while the faulty supply is replaced. Internal diodes isolate the supplies. Each IMF-3 frame has two paralleled connectors, which allows you to connect the frame to another IMF frame or another PSU-101 power supply.

A PSU-101 requires 90 to 260 VAC at 45 to 65 Hz with a maximum dissipation of 80 W. A PSU-101 connected for redundancy requires very little AC current unless it is used.

### PSU-101 Front-Panel Controls and Lights

The front panel of the PSU-101 power supply features two power status lights, two fuses, and an on-off switch for the internal audible alarm.

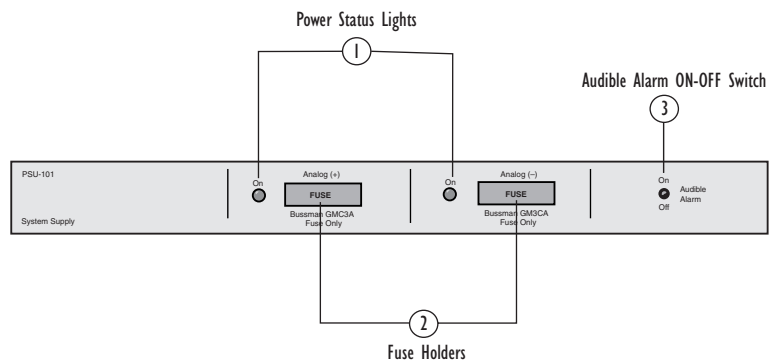

Figure 2-6: Front Panel of a PSU-101 Power Supply

#### ① Power Status Lights

Two green lights indicate the functioning of each of the unit's two power outputs. If a light is out, that output is malfunctioning—call a maintenance person.

#### + Analog

This output provides positive voltage for the analog circuits in the IMF-3 frame. If it fails, system audio would become inoperative or distorted. The green power status light goes out to indicate failure in this output.

### - Analog

This output provides negative voltage for the analog circuits in the IMF-3 frame. If it fails, system audio would become inoperative or distorted. The green power status light goes out to indicate failure in this output.

## ② Fuses

The PSU-101 unit's front panel has a fuse holder for each of the two power outputs. If one of the front-panel power status light goes out, pull the appropriate fuse holder out from the front panel and check the fuse. Spare fuses are provided in the fuse holder if you need to replace a fuse.

*Note: Clear-Com purchases the regulated power supply module used in the PSU-101 as a finished unit. We have no schematics for the module because the manufacturer does not supply them. If the unit fails, the only repair that can be performed is to replace the unit's input fuse.*

## ③ Audible Alarm

Turning the "audible alarm" switch to "on" causes an internal alarm to sound if one of the two power outputs fail. Turning the switch to "off" prevents the internal alarm from sounding.

*Note: The internal alarm is powered from the +8-volt output; if that output fails, the alarm will not work, unless two PSU-101 units are used for redundancy. In redundant operation, if one supply fails, maintenance personnel will be alerted before the second supply can fail. (An external alarm connected to the unit's alarm relay contacts will sound if either of the outputs fails. See "Alarm Relay," in "PSU-101 Rear-Panel Connectors," below.*

## PSU-101 Rear-Panel Connectors

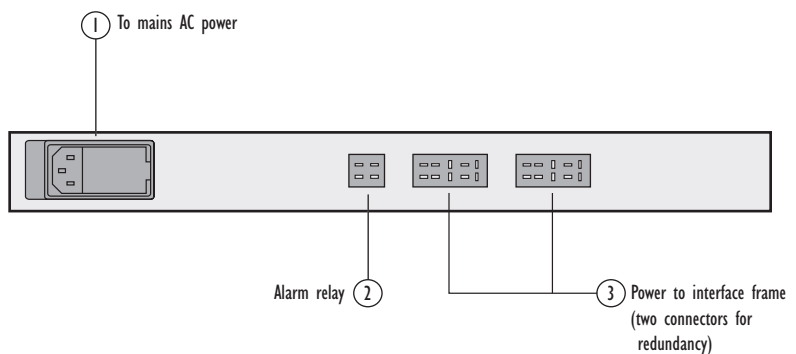

Figure 2-7: Rear Panel of a PSU-101 Power Supply

## ① Connector to Mains AC Power

The PSU-101 power supply runs off of mains AC power.

Using two PSU-101 units, each connected to a separate branch of AC power, provides redundancy in the event of a power failure in one the AC mains branches.

## ② Alarm Relay

The 4-pin Jones-type connector contains a set of relay contacts that you can wire to an external alarm. The contacts will close, and sound the external alarm, any time one of the two power outputs in the PSU-101 becomes inoperable.

Clear-Com recommends that you connect these contacts to the external alarm input of the central matrix frame. If either of the power supplies in the PSU-101 fails, it would cause a system alarm. Status lights on the front of the PSU-101 unit will indicate the failure.

The pin configuration of the alarm relay connector is as follows:

PIN	ASSIGNMENT
1	alarm
2	alarm
3	no connection
4	no connection

Table 2-1: Pin Assignments of PSU-101's Alarm Relay Connector

## ③ Power to Interface Frame (2 Connectors for Redundancy)

Each PSU-101 has two 10-pin Jones-type sockets for connecting DC power cords from the PSU-101 to an interface frame. The factory supplies a DC power cord with each IMF-3 frame.

The second socket is provided for systems that require backup power in case of a failure in one of the PSU-101's power outputs. If your system has been wired for redundant operation, a system will not fail if any one or more of an individual PSU-101's two power outputs fails. The audible alarm and the remote alarm (if wired) will sound, warning you that one or more of the power supply's outputs has failed and needs attention.

You can also use the 10-pin Jones-type sockets for connecting DC power cords between interface frames, in cases where two frames are powered by one PSU-101 power supply.

Figure 2-8 below shows how to connect DC power cords between the power supplies and the interface frames. The illustration on the left shows one PSU-101 unit and two IMF-3 frames. The illustration on the right shows three IMF-3 frames connected to two PSU-101s for redundancy. All of the frames are

connected to the PSU-101 power supply and to each other through the 10-pin Jones-type connectors on the rear panel of the IMF-3 interface frame.

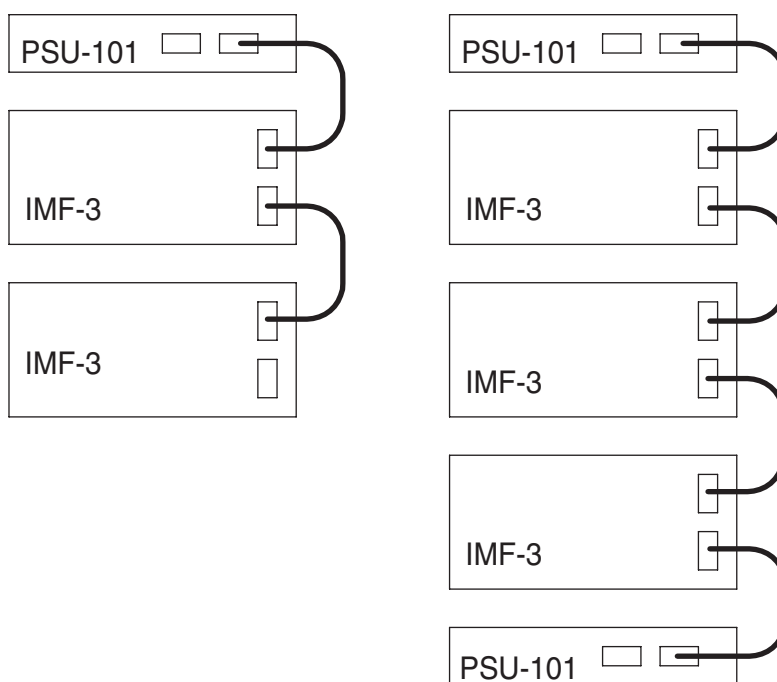

Figure 2-8: Wiring Power Supplies to Interface Frames

## INSTALLING THE PSU-101 POWER SUPPLY

The PSU-101 requires one rack unit (1 RU) in a standard 19-inch (48.26 cm) rack. Allow at least 3 inches (7.62 cm) of clearance behind the PSU-101 to plug in cables.

**CAUTION:** For thermal and safety considerations, when the PSU-101 power supply is mounted on an equipment rack:

- Leave one full rack space (1.75 in. or 4.4 cm) above the unit and one full rack space below the unit.
- Do not block the ventilation holes.
- Leave at least 3 inches (7.62 cm) of clearance behind the unit.

## PSU-101 POWERING OF INTERFACES IN AN IMF-3 FRAME

As a rule-of-thumb, one PSU-101 power supply unit is required for every two IMF-3 frames. There are two exceptions to this rule. The first exception occurs when the frames have a large number of CCI-22 party-line interfaces which require no DC power from the IMF-3 frame. However, an IMF-3 with only CCI-22 interfaces still needs to be connected to a PSU-101 as the IMF-3 frame itself needs some DC power for the circuitry on its rear panel.

The second exception occurs when using multiple TEL-14 telephone interfaces. An IMF-3 interface frame will only power eight TEL-14 interfaces. If more TEL-



14 interfaces are required, you must install them in a second IMF-3 frame with a second power supply.

A PSU-101 requires 90 to 260 VAC at 45 to 65 Hz with a maximum dissipation of 80 W. A PSU-101 connected for redundancy requires very little AC current unless it is used.

Installing two PSU-101 power supplies per application provides redundancy because either of the two PSU-101 power supplies can power a complete system. If one fails, it can be removed without interruption of the entire system. Rear panel connectors provide easy parallel connection to the IMF-3 Interface Module Frame.

The current capacities of the power supplies are as follows:

- 9 V analog                      3.0 amperes
- -9 V analog                    3.0 amperes

The following chart provides the current drain of the +/- analog power supplies for all components in the system. Some devices, such as interfaces, have a varying current depending on the operation of features. In applications where it is possible to activate all operating features of all components used, use the maximum current column for planning.

Component	Average Current	Maximum
IMF-3 Frame	0.20 A	0.20 A
CCI-22	0.00 A	0.00 A
FOR-22	0.07 A	0.15 A
TEL-14	0.28 A	0.37 A
RLY-6	0.10 A	0.15 A
GPI-6	0.02 A	0.02 A
AES-6	0.16 A	0.16 A

Table 2-2: Interface Current Consumption



# 3

## INSTALLATION

### PLACING INTERFACE FRAMES AND POWER SUPPLIES

It is important to place an interface frame in a convenient location, so that you can access the controls on the front panel and the connectors on the rear panel. Leave at least 2 inches (5 cm) of clearance at the rear of an interface frame to allow for cable connectors and access to rear-panel controls.

*Warning: To reduce the risk of fire or electric shock, do not expose an interface frame to rain or moisture.*

Usually interface module frames are located near the matrix, but they can be located farther away. The maximum recommended distance between an Eclipse matrix and an IMF-3 or IMF-102 interface frame is 500 feet (150 meters). The DIF-102 interface frame can be located up to 3,000 feet (1000 meters) from an Eclipse matrix. The DIF-102 should be located in the same building as the Eclipse matrix.

The only interface frame that requires an external power supply is the IMF-3. You can connect an additional external power supply to the IMF-3 interface frame to provide redundancy in the event of power outages or equipment failure.

The IMF-102 frame has an internal power supply with a connector for an additional power supply. The DIF-102 frame is powered by one or two (for redundancy) external AC mains to 24-VDC power supplies via locking DIN connectors on the DIF-102's rear panel.

If redundant PSU-101 power supplies are used for interfaces, mount them together. It is required that you leave an extra rack unit (1.75 in. or 44.45 mm) above and below each external power-supply unit. This allows for needed cooling for larger system loads.

For detailed information on power-supply requirements, refer to Chapter 2, "Powering Interfaces."

### STEP-BY-STEP INSTALLATION

#### IMF-3 INTERFACE FRAME

To install an IMF-3 interface frame:

1. Remove the interface frame from its shipping carton.
2. Remove the blank plates from the front and rear of the slot in which an interface module will be installed.
3. Install the interface module in the appropriate slot. Advance the front half the interface module along the guides in the front part of the slot until it connects to the midplane connector. Advance the rear half of the interface module

along the guides in the rear part of the slot, until it connects with the midplane connector.

4. Install the provided screws on the front and rear panels of the interface module you have just installed, to secure the interface in place in the frame.
5. Repeat steps 2, 3, and 4 for each interface.
6. Install the interface frame in the 19-inch (48.26 cm) rack.
7. Secure the interface frame in the equipment rack with the four provided front-panel screws.
8. Connect an external PSU-101 power supply to the 10-pin Jones connector on the rear panel of the IMF-3 interface frame. A second PSU-101 can be connected for redundancy. See Chapter 2, "Powering Interfaces," for more information on installing and placing the PSU-101 power supply.

*Note: See the section "PSU-101 Power Supply" below for instructions on safe installation of the power supply.*

## IMF-102 AND DIF-102 INTERFACE FRAMES

The IMF-102 and DIF-102 interface frames require similar installation procedures.

To install an IMF-102 or DIF-102 interface frame:

1. Remove the interface frame from its shipping carton.
2. Remove the blank plates from the front and rear of the slot in which an interface module will be installed.
3. Install the interface module in the appropriate slot. Advance the front half of interface along the guides in the front part of the slot until it connects to the midplane connector. Slide the rear half of the interface along the guides in the rear part of the slot, until it connects to the midplane connector.
4. Install the provided screws on the front and rear panels of the interface module you have just installed, to secure the interface module in place in the frame.
5. If you are installing a second interface module, repeat steps 2, 3, and 4 for that module.
6. Install the interface frame in the 19-inch (48.26 cm) rack.
7. Secure the interface frame in the rack with the four provided front-panel screws.
8. **IMF-102 ONLY.** Connect a redundant PSU-101 power supply if necessary. Connect the PSU-101 power supply to the 10-pin Jones connector on the rear panel of the interface frame. See "PSU-101 Power Supply" below for instructions on safely installing and placing the power supply.

## PSU-101 POWER SUPPLY

A PSU-101 can power the interfaces in up to two IMF-3 interface frames, and possibly more, depending on the mix of interface modules and anticipated usage. It also can provide backup power for an IMF-102 interface frame. See Chapter 2, "Powering Interfaces," for more information.

The PSU-101 requires one rack unit (1 RU) in a standard 19-inch (48.26 cm) rack. Allow at least 3 inches (7.62 cm) of clearance behind the PSU-101 to plug in cables.

Connect DC power cable from the 10-pin Jones-type connector on the rear of the PSU-101 power supply to the 10-pin Jones-type connector on the rear of an interface frame. See Chapter 2, "Powering Interfaces," for more information.

**CAUTION:** For thermal and safety considerations, when the PSU-101 power supply is mounted in an equipment rack:

- Leave one full rack space (1.75 in. or 4.4 cm) above the unit and one full rack space below the unit.
- Do not block the ventilation holes.
- Leave at least 3 inches (7.62 cm) of clearance behind the unit.

## WIRING

The following tables give you connector pinout configurations. For operating instructions for each connector's output or input, refer to Chapter 1, "Operating an Interface Frame."

### IMF-102 INTERFACE FRAME

PIN	ASSIGNMENT
1	alarm
2	alarm
3	no connection
4	no connection

Table 3-3: Pin Assignments for the Alarm Relay Connector (4-pin Jones-type)

### DIF-102 DIGITAL-STATION INTERFACE FRAME

PIN	ASSIGNMENT
1	GND
2	+24 volts
3	GND
4	Earth

Table 3-4: Pin Assignments for the PSU1 and PSU2 Connectors (4-pin locking DIN, female)

)

<b>PIN</b>	<b>ASSIGNMENT</b>
1	no connection
2	no connection
3	relay common
4	no connection
5	no connection
6	no connection
7	relay normally closed
8	relay normally open
9	no connection

Table 3-5: Pin Assignments for the Alarm Connector (9-pin D-type, male)

## PSU-101 POWER SUPPLY

<b>PIN</b>	<b>ASSIGNMENT</b>
1	alarm
2	alarm
3	no connection
4	no connection

Table 3-6: Pin Assignments for the Alarm Relay Connector (4-pin Jones-type, female)

# 4 SPECIFICATIONS

## IMF-3 INTERFACE FRAME

<b>Plug-in Module Capacity</b> Quantity	Eleven modules
<b>Connectors (Rear Panel)</b> 10 Pin Jones IEC Power Input Connectors	One, for DC power redundancy Two, one for AC power input, one for AC power redundancy
<b>Power Requirements</b> +9 V Analog - 9 V Analog Max. Dissipation	0.2 amperes (frame only–no modules) 0.2 amperes (frame only–no modules) 50 watts (frame fully loaded)
<b>Operating Environment</b> Temperature Humidity	32° to 122° F (0° to 50° C) 40% to 90% relative humidity (non-condensing)
<b>Dimensions</b> Width Height Depth Weight	19 inches (48.26 cm) 3RU 5.25 inches (13.3 cm) 13.56 inches (34.44 cm) 6.25 lbs. (2.8 kg) (no modules installed)

## IMF-102 INTERFACE FRAME

<b>Plug-in Module Capacity</b> Quantity	Two modules
<b>Connectors (Rear Panel)</b> 10 Pin Jones IEC Power Connector	One, for DC power redundancy One, for AC power input
<b>Power Requirements</b> AC Requirements	90 VAC to 250 VAC, 20 W
<b>Operating Environment</b> Temperature Humidity	32° to 122° F (0° to 50° C) 40% to 90% relative humidity (non-condensing)

### Dimensions

Width	19 in. (48.26 cm)
Height	1 RU 1.75 in. (4.4 cm)
Depth	13.56 in. (34.44 cm)
Weight	6.25 lbs. (2.8 kg) (no modules installed)

## DIF-102 INTERFACE FRAME

### Plug-in Module Capacity

Quantity	Two modules
----------	-------------

### Connectors (Rear Panel)

4 Pin Locking DIN, female	Two, one for DC power input, and one for redundant power
9 Pin D-type, male	Alarm

### Power Requirements

AC Requirements	90 VAC to 264 VAC, 47–63 Hz, 45 W maximum (when using 1 or 2 of 150/UNI-DIN4)
DC Requirements	24 VDC, $\pm 2\%$ @ 1.88 A maximum (x 1 or 2)

### Operating Environment

Temperature	32° to 104° F (0° to 40° C)
Humidity	40% to 90% relative humidity (non-condensing)
Storage	–55° to +70° C (–67° to +158° F)

### Dimensions

Width	19 in. (48.26 cm)
Height	1 RU 1.75 in. (4.4 cm)
Depth	17.11 in. (43.47 cm)

## PSU-101 POWER SUPPLY

### Front Panel Controls and Indicators

Indicators	2 green power-output indicator leds
Fuses	2 fuseholders for the two power supplies
Switches	1 audible alarm enable

### Rear Panel Connectors and Controls

Output Conn.	2 300 Series 10 Pin Cinch Jones
Alarm Out	1 300 Series 4 Pin Cinch Jones
Power In Conn.	IEC 320 Type
Fuse	AC Mains



### **Internal Regulated Power Supplies**

Quantity	2
Type	Switching
Output Volt.	8.4 VDC
Output Cur.	4.4 Amp. Max.
Output fuse	3.0 Amp Both Supplies

### **Mains AC Power Input**

Voltage	90 - 260 VAC
Power	90 Volt-Amps Max.
Frequency	50 to 60 Hz
Fusing	2.0 Amp.

### **Operating Environment**

Temperature	0° to 50° C (32° to 122° F)
Humidity	20% to 90% Relative Humidity (Non-Condensing)

### **Package Dimensions**

Height	1.75 inches (4.45 cm), (1 RU)
Width	19.0 inches (48.26 cm)
Depth	7.75 inches (19.69 cm)
Weight	4.0 lbs. (2.0 kg)



# LIMITED WARRANTY

Vitec Group Communications (VGC) warrants that at the time of purchase, the equipment supplied complies with any specification in the order confirmation when used under normal conditions, and is free from defects in workmanship and materials during the warranty period.

During the warranty period VGC, or any service company authorized by VGC, will in a commercially reasonable time remedy defects in materials, design, and workmanship free of charge by repairing, or should VGC in its discretion deem it necessary, replacing the product in accordance with this limited warranty. In no event will VGC be responsible for incidental, consequential, or special loss or damage, however caused.

## WARRANTY PERIOD

The product may consist of several parts, each covered by a different warranty period. The warranty periods are:

- Cables, accessories, components, and consumable items have a limited warranty of 90 days.
- Headsets, handsets, microphones, and spare parts have a limited warranty of one year.
- UHF wireless IFB products have a limited warranty of one year.
- UHF wireless intercom systems have a limited warranty of three years.
- All other Clear-Com and Drake brand systems and products, including belt packs, have a limited warranty of two years.

The warranty starts at the time of the product's original purchase. The warranty start date for contracts which include installation and commissioning will commence from the earlier of date of the Site Acceptance Test or three months from purchase.

## TECHNICAL SUPPORT

To ensure complete and timely support to its customers, VGC's User Support Center is staffed by qualified technical personnel. Telephone and email technical support is offered worldwide by the User Support Center.

The User Support Center is available to VGC's customers during the full course of their warranty period.

Instructions for reaching VGC's User Support Centers are given below.

**Telephone for Europe, Middle East and Africa:** +49 40 6688 4040 or +44 1223 815000

*Return Material Authorization (RMA) numbers are required for all returns.*

*Both warranty and non-warranty repairs are available.*

Telephone for the Americas and Asia: +1 510 337 6600

Email: [vitec.support@AVC.de](mailto:vitec.support@AVC.de)

Once the standard warranty period has expired, the User Support Center will continue to provide telephone support if you have purchased an Extended Warranty.

For latest contact information please refer to the Service and Support section at [www.clearcom.com](http://www.clearcom.com).

## **WARRANTY REPAIRS AND RETURNS**

Before returning equipment for repair, contact a User Support Center to obtain a Return Material Authorization (RMA). VGC representatives will give you instructions and addresses for returning your equipment. You must ship the equipment at your expense, and the support center will return the equipment at VGC's expense.

For out-of-box failures, use the following contact information:

### **Europe, Middle East and Africa**

Tel: +44 1223 815000 Email: [customerservicesEMEA@vitecgroup.com](mailto:customerservicesEMEA@vitecgroup.com)

### **North America, Canada, Mexico, Caribbean & US Military**

Tel: +1 510 337 6600 Email: [customerservicesUS@vitecgroup.com](mailto:customerservicesUS@vitecgroup.com)

### **Asia Pacific & South America**

Tel: +1 510 337 6600 Email: [customerservicesAPAC@vitecgroup.com](mailto:customerservicesAPAC@vitecgroup.com)

VGC has the right to inspect the equipment and/or installation or relevant packaging.

For latest contact information please refer to the Service and Support section at [www.clearcom.com](http://www.clearcom.com).

## **NON-WARRANTY REPAIRS AND RETURNS**

For items not under warranty, you must obtain an RMA by contacting the User Support Center. VGC representatives will give you instructions and addresses for returning your equipment.

You must pay all charges to have the equipment shipped to the support center and returned to you, in addition to the costs of the repair.

## **EXTENDED WARRANTY**

You can purchase an extended warranty at the time of purchase or at any time during the first two years of ownership of the product. The purchase of an extended warranty extends to five years the warranty of any product offered with a standard two-year warranty. The total warranty period will not extend beyond five years.

**Note:** VGC does not offer warranty extensions on UHF wireless intercom systems, or on any product with a 1-year or 90-day warranty.

## **LIABILITY**

THE FOREGOING WARRANTY IS VGC'S SOLE AND EXCLUSIVE WARRANTY. THE IMPLIED WARRANTY OF MERCHANTABILITY AND FITNESS FOR A PARTICULAR PURPOSE AND ANY OTHER REQUIRED IMPLIED WARRANTY SHALL EXPIRE AT THE END OF THE WARRANTY PERIOD. THERE ARE NO OTHER WARRANTIES (INCLUDING WITHOUT LIMITATION WARRANTIES FOR CONSUMABLES AND OTHER SUPPLIES) OF ANY NATURE WHATSOEVER, WHETHER ARISING IN CONTRACT, TORT, NEGLIGENCE OF ANY DEGREE, STRICT LIABILITY OR OTHERWISE, WITH RESPECT TO THE PRODUCTS OR ANY PART THEREOF DELIVERED HEREUNDER, OR FOR ANY DAMAGES AND/OR LOSSES (INCLUDING LOSS OF USE, REVENUE, AND/OR PROFITS). SOME STATES DO NOT ALLOW THE EXCLUSION OR LIMITATION OF INCIDENTAL OR CONSEQUENTIAL DAMAGES OR THE LIMITATION ON HOW LONG AN IMPLIED WARRANTY LASTS, SO THE ABOVE LIMITATIONS MAY NOT APPLY TO YOU. IN ANY EVENT, TO THE MAXIMUM EXTENT PERMITTED UNDER APPLICABLE LAW, VGC'S LIABILITY TO CUSTOMER HEREUNDER SHALL NOT UNDER ANY CIRCUMSTANCES EXCEED THE COST OF REPAIRING OR REPLACING ANY PART(S) FOUND TO BE DEFECTIVE WITHIN THE WARRANTY PERIOD AS AFORESAID.

This warranty does not cover any damage to a product resulting from cause other than part defect and malfunction. The VGC warranty does not cover any defect, malfunction, or failure caused beyond the control of VGC, including unreasonable or negligent operation, abuse, accident, failure to follow instructions in the manual, defective or improperly associated equipment, attempts at modification and repair not approved by VGC, and shipping damage. Products with their serial numbers removed or defaced are not covered by this warranty.

This warranty does not include defects arising from installation (when not performed by VGC), lightning, power outages and fluctuations, air conditioning failure, improper integration with non-approved components, defects or failures of customer furnished components resulting in damage to VGC provided product.

This limited warranty is not transferable and cannot be enforced by anyone other than the original consumer purchaser.

This warranty gives you specific legal rights and you may have other rights which vary from country to country.

